

2. Supply fan

This application macro is for supply fan applications where the supply fan brings fresh air into the room according to the signals received from the transducer. See the following figure.

When using a direct speed reference in AUTO mode, the speed reference must be connected to analog input 1 (AI1) and the START command is given with digital input 1 (DI1). In HAND/OFF mode, the speed reference and START command are given through the control panel.

If process PI(D) is used, the feedback signal must be connected to analog input 2 (AI2). Setpoint is set from the control panel as default but it also can be changed to analog input 1. Process PI(D) must be commissioned and adjusted with parameters (Group 40) or using the PID control assistant (recommended).

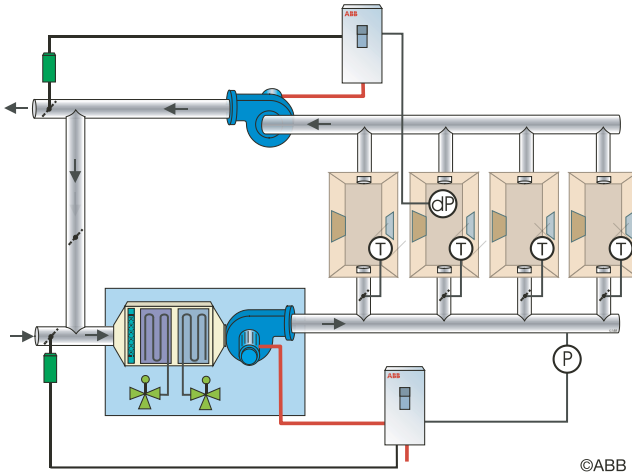

Supply Fan

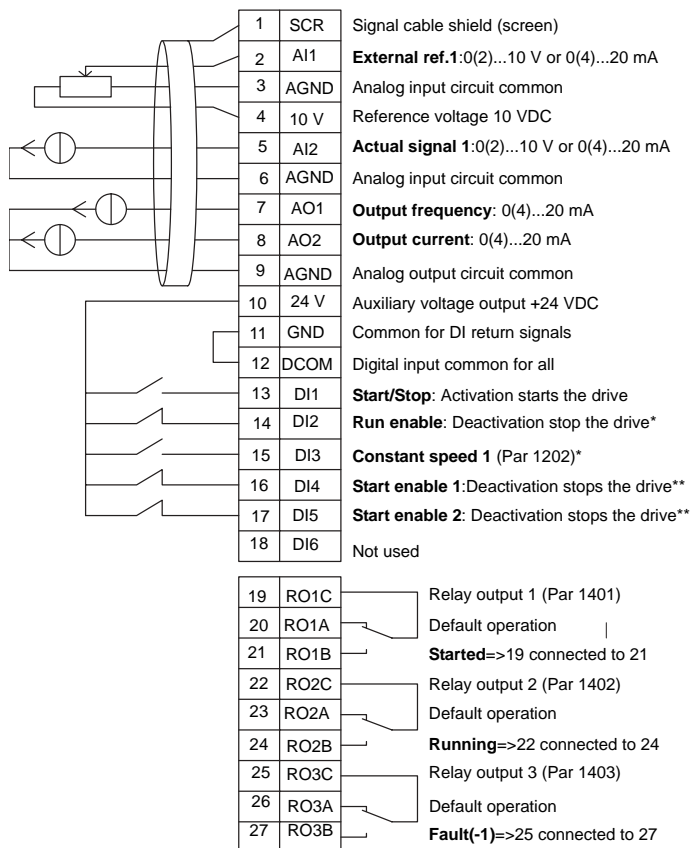

*Not available if PID is activated

**Disable/enable with parameters 1601, 1608 and 1609

Note! Drive starts only if possible protection functions (Run enable or Start enable 1 and 2) are activated from I/O or disabled with parameters.